



italkrane

THE HIGHEST LEVEL OF EXPLOSION PROTECTION

ELECTRIC TRAVELLING TROLLEYS MOVE SERIES



MO AND MOc SERIES TRAVEL TROLLEYS

The MO trolley series is designed to operate under the most severe conditions expected in the industrial lifting applications. It is available in electrically, geared or push versions. The MOc version allows the hoist to travel on curved paths or curved areas.

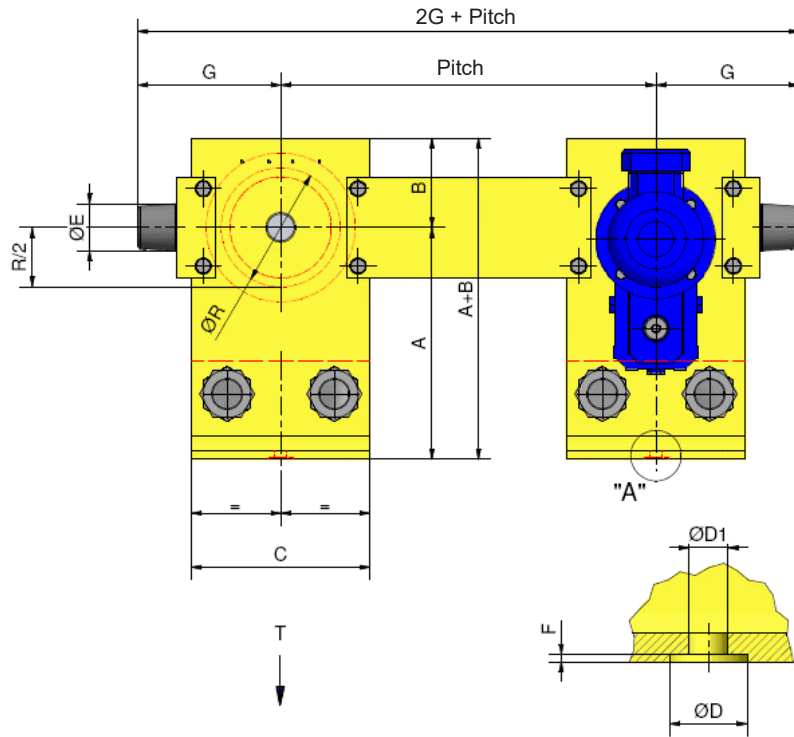

MO - ELECTRIC TRAVELLING TROLLEYS MOVE SERIES

Size	Capacity (t)	A	B	B ₁	C	D	D ₁	E	F	G	I	L
MO 100	1	228	70	160	150	30 ¹	12.25	40	2	135	21	80
MO 125	2	251	95	160	180	30 ¹	12.25 16.25	60	3	150	30	80 100
MO 160	4	313	120	200	220	30 ¹ 40 ¹	16.25 20.25	60	3	185	32	100 120
MO 200	8	390	150	230	300	40 ¹ 50 ¹	20.25 24.25	80	4	240	40	120 150
MO 250	16	460	185	275	370	50 ¹	24.5	80	3	265	40	150

ifting applications. Robust and reliable, equipped with wheels mounted on life lubricated bearings, it is avai-
of all kinds. Both versions are available in Ex execution suitable for operation in explosion-proof classified

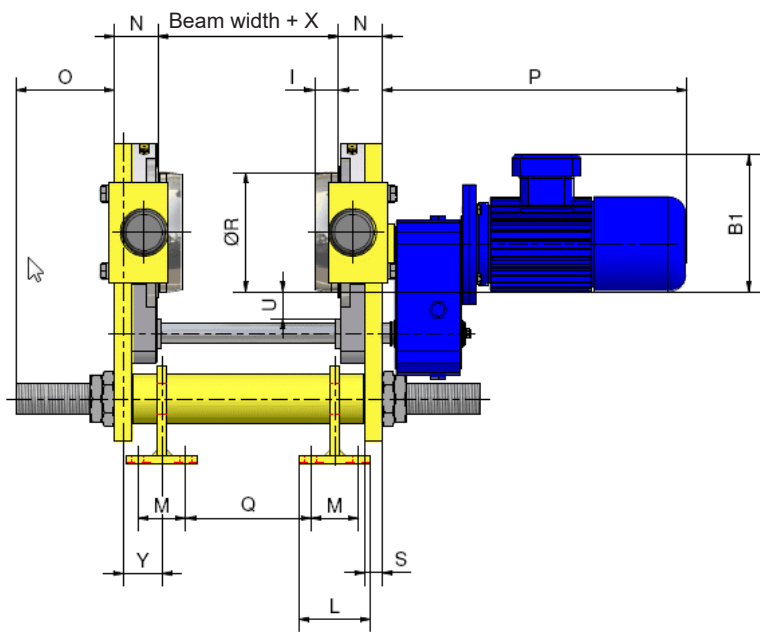

DETAIL "A"

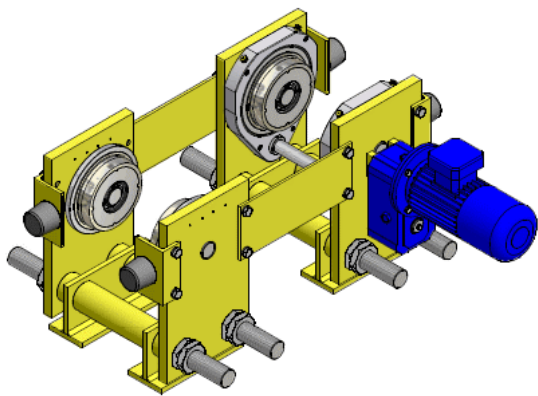

M	N	O	P	Q standard	R	S	U	X	Y max	WIDTH MIN (mm)
50	47	60	400	30/130/230	100	20	21	3	50	65
50 60	54	70	400	30/130/230 40/160/280	125	20	23	3	60	90
60 80	60	85	450	40/160/280 50/210/370	160	25	33	3	80	90
80 100	74	115	520	50/210/370 100/300/500	200	30	45	3	100	125
100	78,5	115	520	100/300/500	250	20	55	3	130	140

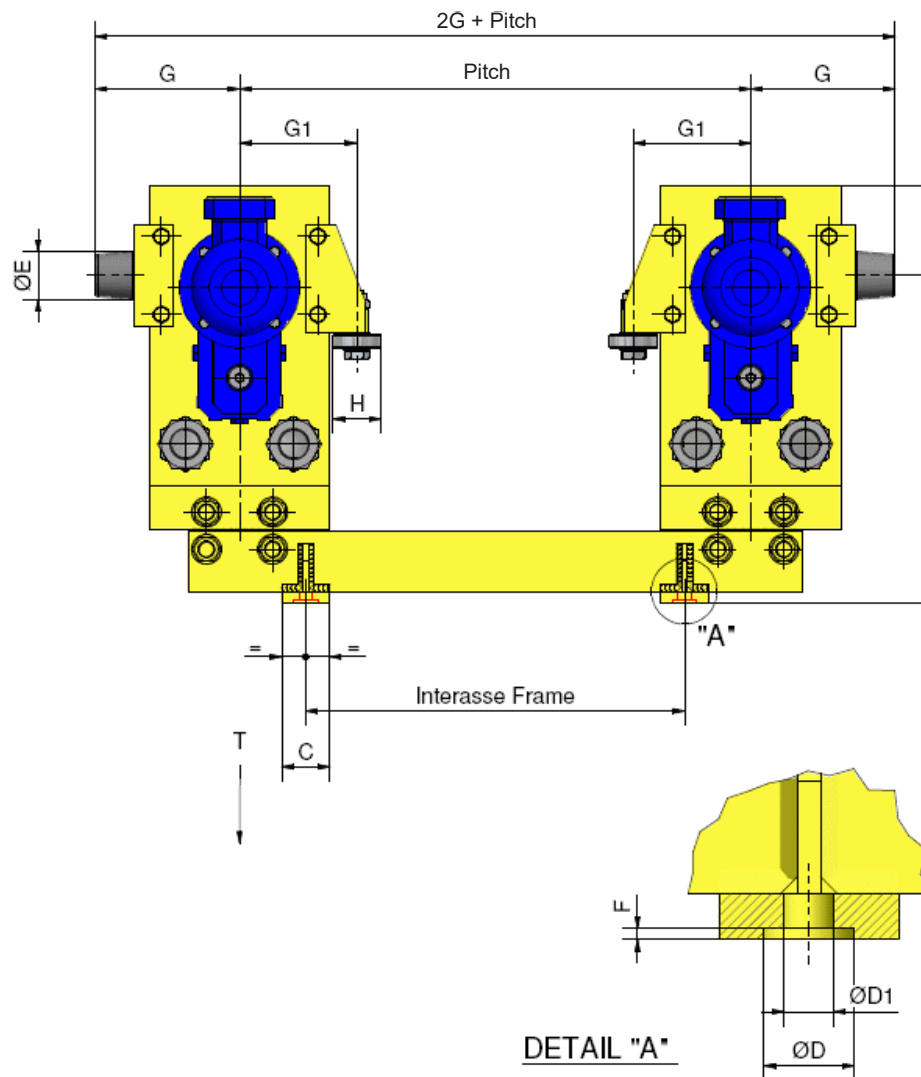

MOc - ELECTRIC TRAVELLING TROLLEYS SERIES "MOVE" FOR CURVED MONORAIL

Size	Capacity (t)	A	B	B ₁	C	D	D ₁	E	F	G	G ₁	H
MOc 100	1	347	70	160	50	30 ¹	12.25	40	2	135	105	52
MOc 125	2	377	95	160	50	30 ¹	12.25 16.25	60	3	150	125	62
MOc 160	4	495	120	200	80	30 ¹ 40 ¹	16.25 20.25	60	3	185	150	72
MOc 200	8	545	150	230	80	40 ¹ 50 ¹	20.25 24.25	80	4	240	195	80
MOc 250	16	672	185	275	80	50 ¹	24.5	80	3	265	232	90

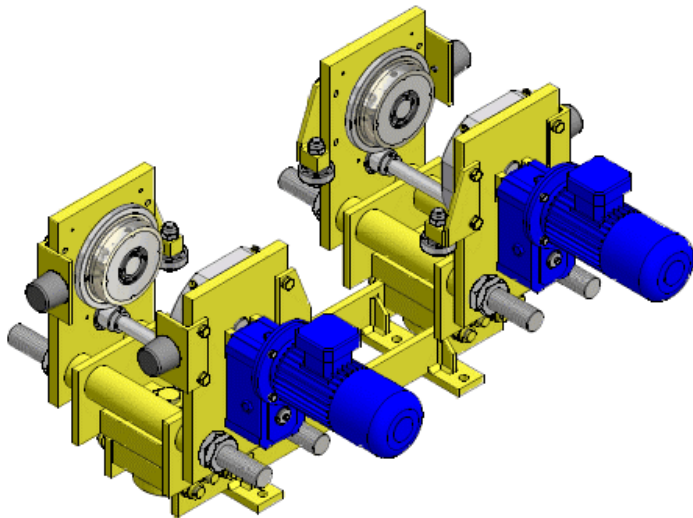
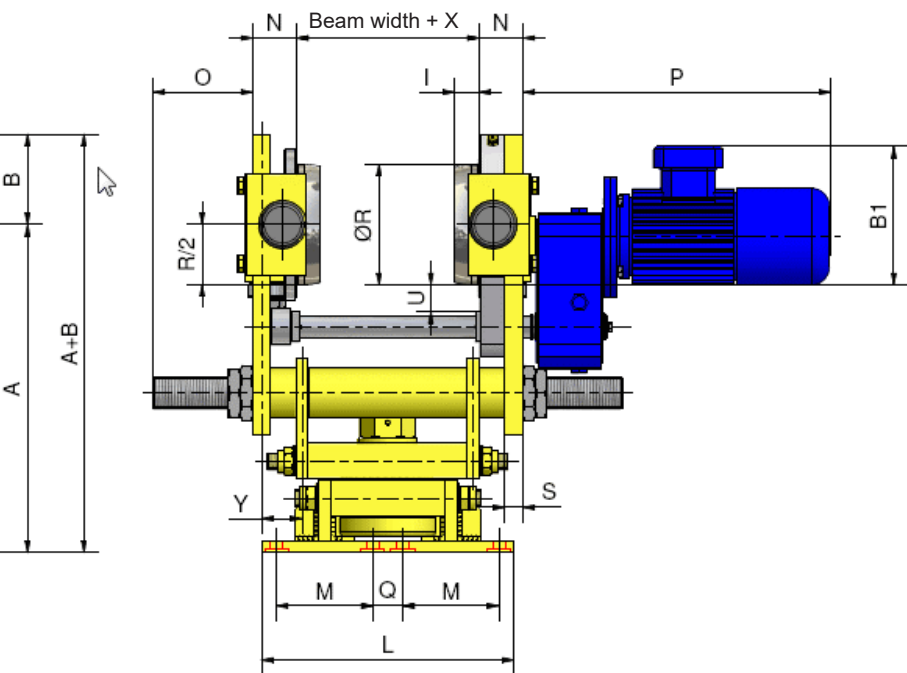

I	L	M	N	O	P	Q standard	R	S	U	X	Y max	WIDTH MIN (mm)
21	270	100	47	60	400	30	100	20	21	3	50	65
30	270 320	100 120	54	70	400	30 40	125	20	23	5	60	90
32	320 260	120 80	60	85	450	40 50	160	25	33	5	80	90
40	420 360	160 100	74	115	520	50 100	200	30	45	5	100	125
40	360	100	78,5	115	520	100	250	20	55	5	130	140



ITALKRANE lifting equipment

Bridge cranes

Electric wire rope hoists

Winches

Special machines

Chain hoists

Crane kit

Components

Via Monza, 13 - 20041 - Bussero (Milano – Italy)

+39 02 92 97 21 - italkrane@italkrane.it

Sales: chiara.giovanetti@italkrane.it

After sales: banfi@italkrane.it

Spare parts: bolzoni@italkrane.it